

# MCP-35

## PREDETERMINING ELECTRIC COUNTER

### DESCRIPTION

The MCP-35 Series is an additive or subtractive preset counter that has a solid and robust construction which makes it ideal for applications demanding strong resistance from shock and vibration.

Desired preset value can easily be set with a push of a button. With each input pulse, the counter adds/subtracts one count. When the preset number is reached, an output signal is sent out through a built-in relay.

Manual or Electric reset types are available.

Ideal for applications that requires monitoring, controlling of various automatic machines such as printing machines, textile machines, etc.



MCP-35

### MODEL SELECTION

TYPE	MODEL	DIGITS	RESET	WEIGHT
ADDITION PRESET COUNTER	<b>MCP - 35</b>	5	Manual	880g

### SPECIFICATIONS

Model	<b>MCP - 35</b>
Power Source	AC100 / 200 V (50 / 60 Hz) convertible
Voltage Fluctuation	± 10%
Power Consumption	Count : 8.9 - 10.5 VA (AC)
Continuous Energizing	Count : less than 5 minutes
Counting Method	One pulse - One count(energizing - 1/2count,unenergized - 1/2count)
Counting Speed	15 Hz (maximum)
Pulse Width	33msec. (Make/Duty: 1:1)
Display	Addition Count : 4.3 x 2.5mm (white) Preset Setting : 3.0 x 1.6 (yellow) Subtraction Count : 4.5 x 4.0 (white)
Reset Time	Manual - Pushbutton
Output	1C Relay AC 250V 5A
Connection	Screw Terminal
Operating Temperature	-5°C - +40°C (non-freezing)
Operating Humidity	85%RH maximum (non-condensing)
Test Voltage	AC1,500V for 1 minute
Insulation Resistance	20MΩ minimum(500VDC megger)
Vibration	Endurance : 16.7Hz, double amplitude 4mm / Malfunction : 10 ~ 55Hz, double amplitude 0.5mm
Shock	Endurance : 300 m/s <sup>2</sup> (30G) / Malfunction : 50 m/s <sup>2</sup> (5G)
Construction	Panel : Die - cast 7.5BG6/1.5

※ Repetitive short time intervals between resets may cause the reset coil to burn. To prevent this, make sure that the next reset is approximately 20 times the On time of the previous reset. (Ex.: If the reset ON time is 1 second, the next reset should be at least 20 seconds after.)

## SETTING THE PRESET VALUE

### FOR MCP-35 SERIES

1. Press the Reset Button (R) to bring the display (white figures) to zero position.
2. While pressing the Lock Button (black button), press the individual digit keys to set the desired preset value. Notice the preset display (yellow figures) increment every push of the button.
3. When the desired preset value is set, release the Lock Button (black button).
4. Press once again the Reset Button (R) before starting operation of counter.

## CONNECTION

### MCP-35

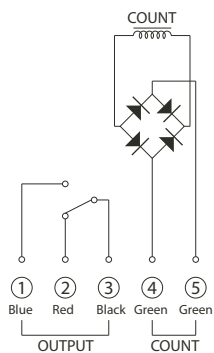

## DIMENSIONS

### MCP-35

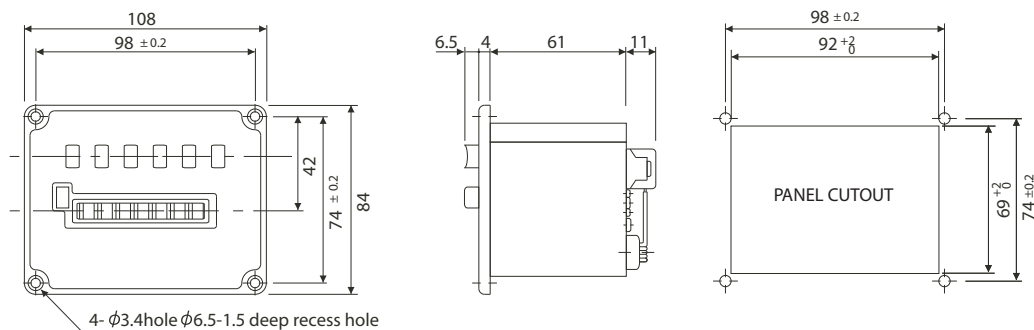

This catalog was last revised Jan. 19, 2011.  
\*Subject to change without prior notice.  
All Rights Reserved, Copyright © 2011, LINE SEIKI CO., LTD.



**LINE SEIKI CO., LTD.**

Address : 37-7, Chuo-Cho, 2-Chome, Meguro-ku  
Tokyo 152-0001 JAPAN  
Contacts : Tel: +81-3-3716-5151 Fax: +81-3-3710-4552  
E-mail: [webtrade@line.co.jp](mailto:webtrade@line.co.jp)  
URL : <http://lineseiki.com/>